

# MVSI-450 series

## ISO-1 SOLENOID VALVE

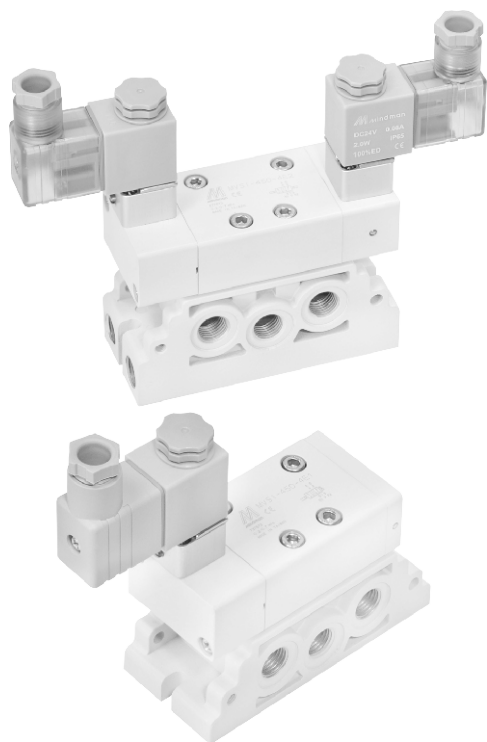

Mindman



### Specification

Model	4E1	4E2
No. of port	5	
No. of position	2	
Medium	Air	
Operating pressure range	0.2~0.7 MPa	
Proof pressure	1 MPa	
Effective orifice	27 mm <sup>2</sup>	
Response time	40 ms	
Ambient temperature	-5~+50°C (No freezing)	
Voltage	AC110V, 220V (50/60)Hz, DC24V	
Power consumption	AC=6/4.9VA, DC=2.5W	
Available voltage range	±10%	
Insulation class	F class	
Weight	380 g	540 g

### Order example of valve

MVSI — 450 — 4E2 — AC110 — L

MODEL

BODY WIDTH

VOLTAGE

AC220V(50/60)Hz  
AC110V(50/60)Hz  
DC24V

Blank: DIN connector

L: DIN connector with LED indicator

E: Explosion protection (Table 1)

(E type use black coil)

4: 4 way(5 port)

E1: Single Solenoid  
E2: Double Solenoid

Table 1

### Property for explosion-proof type

Anti-explosion class	EEx m II T4
Voltage	AC110V, 220V.(50/60)Hz, DC24V.
Power consumption	AC=4.4VA DC=5W
Available voltage range	±10%
Insulation class	F class

### Flow features

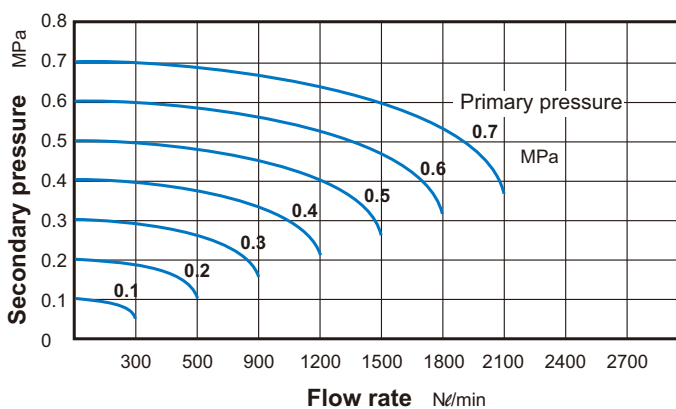

# MVSI-450 Dimensions

## ISO-1 SOLENOID VALVE



Mindman

### MVSI-450-4E1

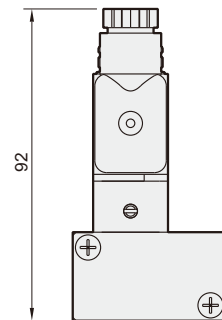
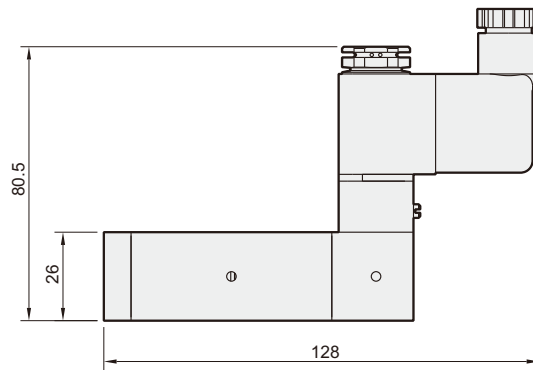
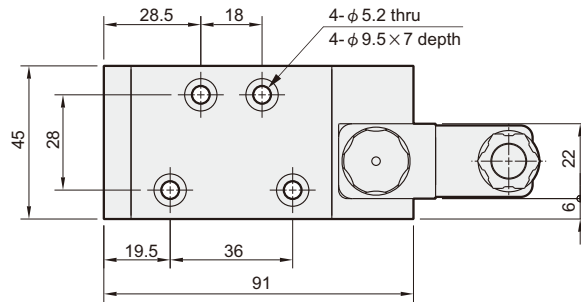
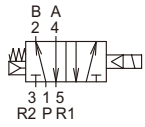

### MVSI-450-4E2

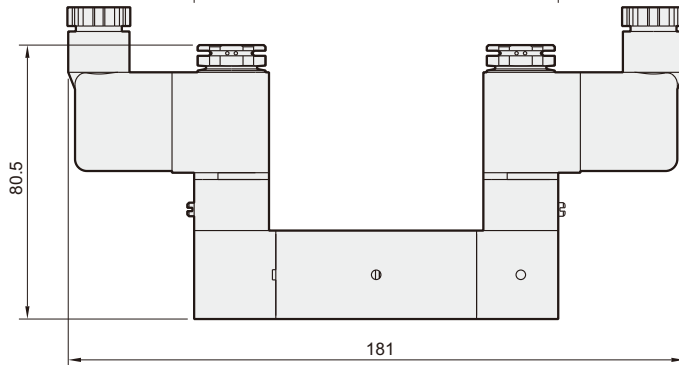
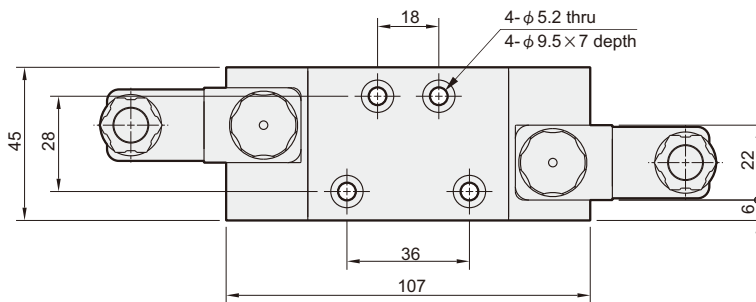
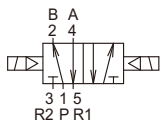

### Accessories

