

Features

- Simple design makes this press our most popular export unit.
- Strong and reliable in operation.
- Universal construction enables unit to meet the most demanding and varied applications.
- Safe in operation.

Features of design

- Open height: The distance between working table and cylinder spindle can be changed and adjusted according to the height of cylinder base so as to match for the height of the work pieces.
- Light weight: As light weight of this unit, it is easy to move without affecting to the working efficiency.
- Offering A.B.C. three kinds of base for choice.

Operation & maintenance (for all series)

- The control knob can adjust the descending speed of die spindle. (Quicker speed for counter clockwise direction, but lower speed for clockwise direction.), if high speed descending is required, quick exhaust valve can be used.
- Please fill in lubricant with international recommended oil VG-32, adjust properly the oil capacity of the lubricator.
- When connecting of pneumatic hose, be sure to clean all impurities, such as: water, dust, etc.in the hose.
- The adjustment of output can be regulated by pressure reducing valve, and its pressure value will be shown as the pressure gauge.

Order example

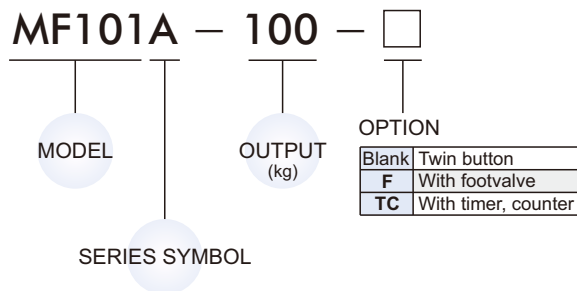

Directions of operation

- After connect power and air compressor, be sure to have all circuits in the working condition.
- The hand pressed button switch (or foot switch), the shaft rod will be descending to carry out the pressing. When hand releases (or foot leaves), the shaft rod will be ascending.

Specification

Item Model	Output (kg)	Stroke (mm)	Cylinder dia (mm)	Stroke adj. (mm)	Air consumption (ℓ/min)	Piping bore (Rc)	Open height (mm)	Weight (kg)
MF100-60	65	50	50	30	1.2	1/4	150	20
MF100-100	120	50	63	30	2	3/8	150	20.3
MF101A-100	120	100	63	30	4	3/8	200	39
MF101A-200	200	100	80	30	6	3/8	200	43
MF101A-300	300	100	100	30	10	3/8	200	47
MF102-500	500	100	125	30	16	1/2	250	90
MF102-800	750	100	150	30	23	1/2	250	103
MF103A-1500	1350	100	200	30	42	3/4	300	200
MF103B-3000	2700	100	200×2	30	65	3/4	300	245

Air press circuit (for all series)

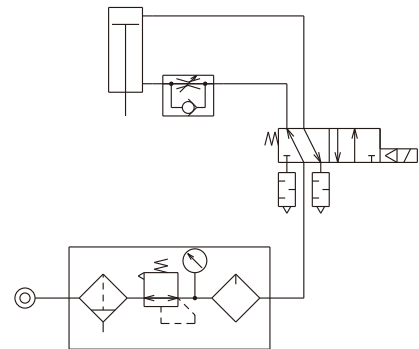

MF100-60

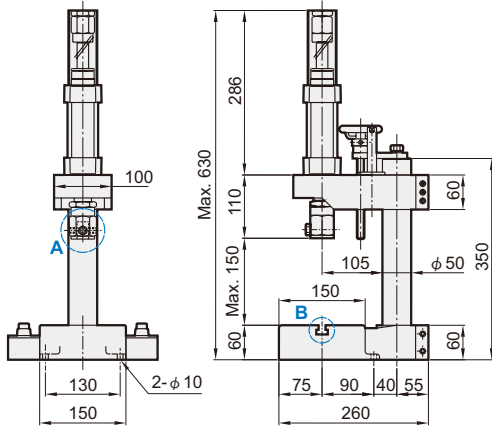
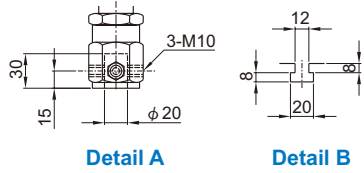

MF100-100

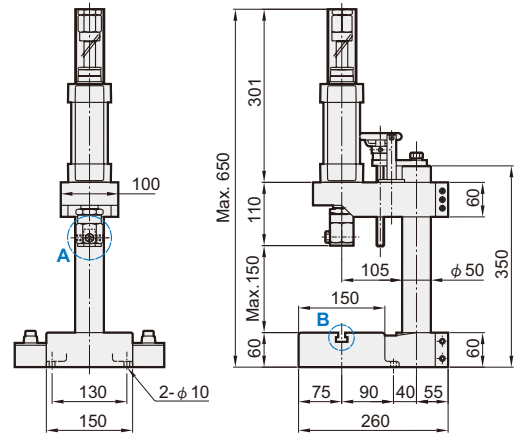
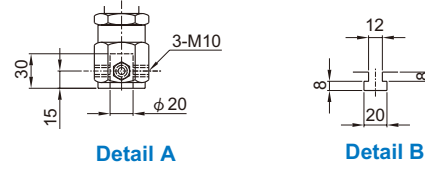

MF101A-100

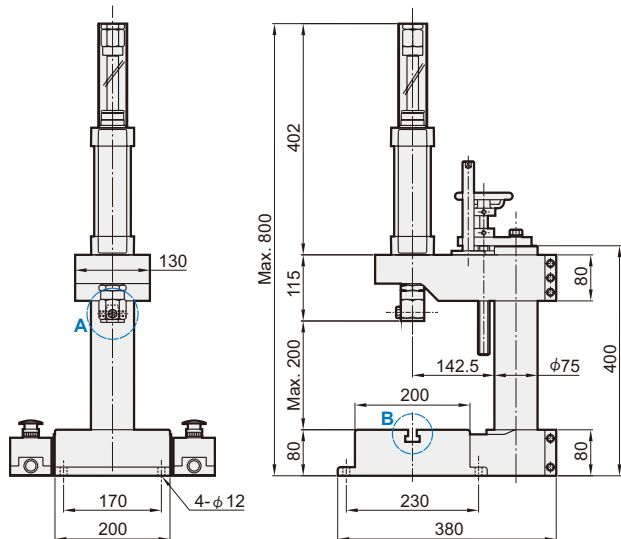
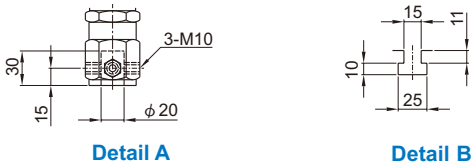

MF101A-200

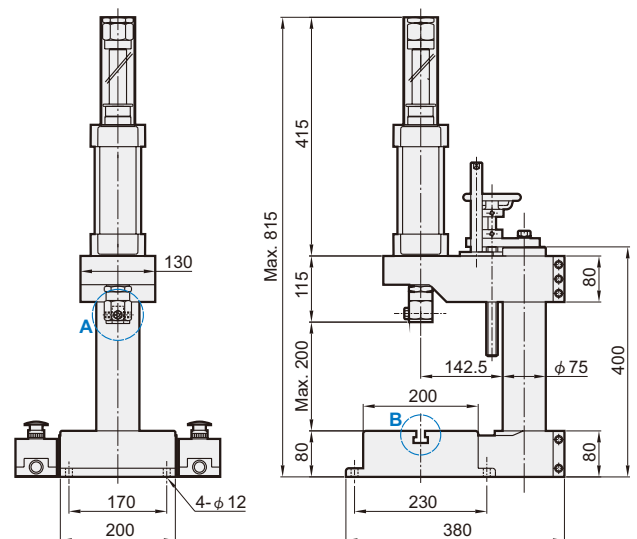
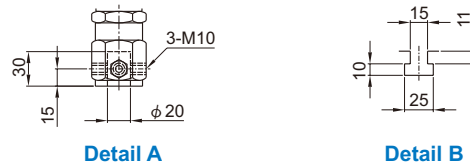

MF101A-300

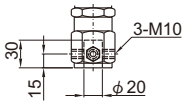

Detail A

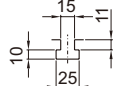

Detail B

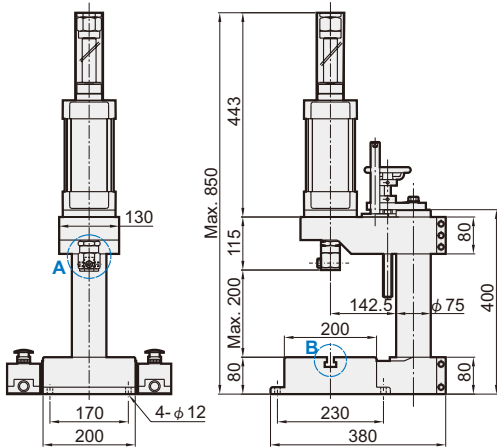

MF102-500

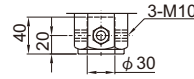

Detail A

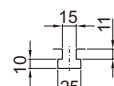

Detail B

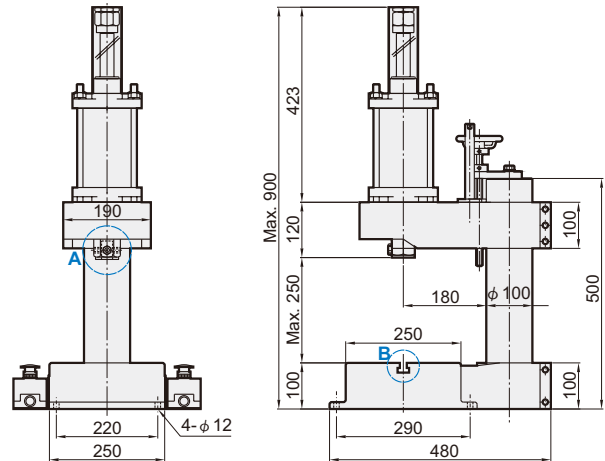

MF102-800

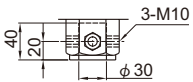

Detail A

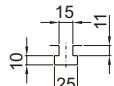

Detail B

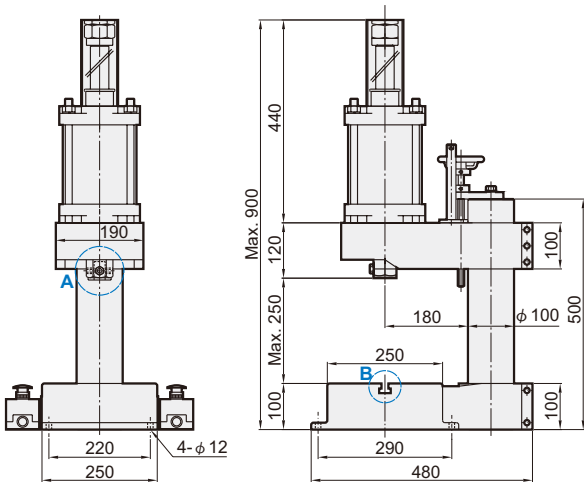

MF103A-1500

MF103B-3000

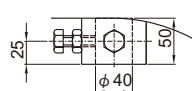

Detail A

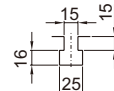

Detail B

Code Tube I.D.	C	D
MF103A	459	1109
MF103B	671	1321

