

# METS-6M series

## SLIDER ELECTRIC CYLINDER - BALL SCREW DRIVE (WITHOUT MOTOR)



mindman



Sensor layout

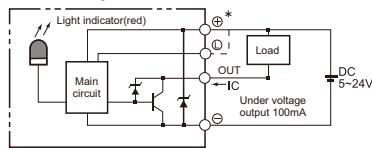

### Specification

| Model                           |          | METS-6M            |   |    |
|---------------------------------|----------|--------------------|---|----|
| Repeatability (mm)              |          | ±0.01              |   |    |
| Belt lead (mm)                  |          | 2                  | 5 | 10 |
| Stroke (mm)                     |          | 100~800 / 50 pitch |   |    |
| Ball screw φ (mm)               |          | C7 φ 12            |   |    |
| High rigidity linear guide (mm) |          | W42×H9.5           |   |    |
| Home sensor                     | Outside  | EE-SX672 (NPN)     |   |    |
|                                 | Built in | -                  |   |    |

| Stepping motor           |            | □57    |     |     |
|--------------------------|------------|--------|-----|-----|
| Max. speed (mm/s)        |            | 16     | 41  | 83  |
| Rated thrust (N)         |            | 1225   | 490 | 245 |
| Max. payload (kg)        | Horizontal | 30     | 30  | 15  |
|                          | Vertical   | 15     | 10  | 5   |
| Coupling (mm)            |            | 7×6.35 |     |     |
| Max. static torque (N.m) |            | 0.39   |     |     |

| Servo motor       |            | 100 W |     |     |
|-------------------|------------|-------|-----|-----|
| Max. speed (mm/s) |            | 100   | 250 | 500 |
| Rated thrust (N)  |            | 854   | 341 | 170 |
| Max. payload (kg) | Horizontal | 30    | 30  | 15  |
|                   | Vertical   | 15    | 10  | 5   |
| Coupling (mm)     |            | 7×8   |     |     |

※ When the stroke is longer than 600mm, resonance of the ball screw may occur depending on the operation conditions (critical speed). In this case, reduce the speed setting on the program by referring to the maximum speeds shown.

### Order example

**METS-6M** — **L05** — **100** — **BC** — **57M** — **C4** — **M5** — **0001**

Model Spec. Stroke 100~800 mm 50 mm pitch M10B Installation hole Special order no.

|           |                   |
|-----------|-------------------|
| —         | Upwards lock type |
| <b>M5</b> | Down lock type    |

| Ball screw brand        | Ball screw lead                                     | Motor position  | Stepping motor brand  | Home sensor   | Limit sensor  |
|-------------------------|---|---|---|---|---|
| <b>L</b> T-Standard MIT | <b>02</b> 2 mm<br><b>05</b> 5 mm<br><b>10</b> 10 mm | <b>BC</b> Exposed<br><b>BM</b> On lower side<br><b>BR</b> On right side<br><b>BL</b> On left side | □42 STEP motor<br><b>57M</b> Tamagawa (TS3653N1E2)<br>Oriental (PK264-02A)<br>Sanyo (103H7121-0140) | Out side<br><b>C</b> Motor side<br><b>D</b> Opposite motor side<br>No sensor<br><b>E</b> None | Out side<br><b>3</b> 1 Pc<br><b>4</b> 2 Pcs<br>No sensor<br><b>5</b> None |

| Motor brand, power output, brakes |            |           |               |
|-----------------------------------|------------|-----------|---------------|
| 100W SERVO motor                  |            |           |               |
| <b>M</b>                          | Mitsubishi | <b>10</b> | 100W <b>B</b> |
| <b>P</b>                          | Panasonic  |           |               |
| <b>Y</b>                          | Yaskawa    |           |               |
| <b>T</b>                          | Delta      |           |               |

※ Need not show **B** with no brake.

### Allowable overhang N.m

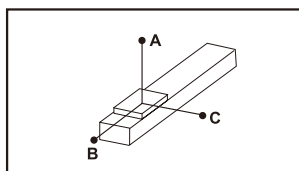

Unit: mm

| Horizontal installation |      | A   | B   | C   |
|-------------------------|------|-----|-----|-----|
| Lead 2                  | 10kg | 898 | 34  | 120 |
|                         | 30kg | 350 | 0   | 27  |
|                         | -    | -   | -   | -   |
| Lead 5                  | 10kg | 374 | 33  | 109 |
|                         | 30kg | 159 | 0   | 25  |
|                         | -    | -   | -   | -   |
| Lead 10                 | 3kg  | 624 | 125 | 335 |
|                         | 8kg  | 273 | 41  | 121 |
|                         | 15kg | 216 | 24  | 77  |

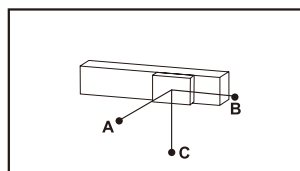

Unit: mm

| Wall installation |      | A   | B  | C   |
|-------------------|------|-----|----|-----|
| Lead 2            | 15kg | 25  | 0  | 110 |
|                   | 30kg | 0   | 0  | 0   |
|                   | -    | -   | -  | -   |
| Lead 5            | 5kg  | 204 | 45 | 530 |
|                   | 10kg | 72  | 0  | 245 |
|                   | 30kg | 0   | 0  | 0   |
| Lead 10           | 3kg  | 293 | 96 | 510 |
|                   | 8kg  | 89  | 14 | 210 |
|                   | 15kg | 43  | 0  | 130 |

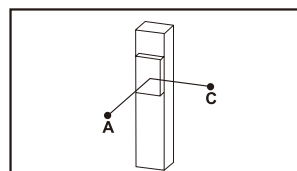

Unit: mm

| Vertical installation |      | A   | C   |
|-----------------------|------|-----|-----|
| Lead 2                | 5kg  | 58  | 58  |
|                       | 15kg | 0   | 0   |
|                       | -    | -   | -   |
| Lead 5                | 2kg  | 171 | 172 |
|                       | 4kg  | 73  | 74  |
|                       | 10kg | 23  | 26  |
| Lead 10               | 1kg  | 355 | 352 |
|                       | 2kg  | 165 | 165 |
|                       | 5kg  | 70  | 72  |

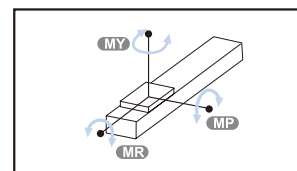

Unit: N.m

| Static loading moment |    |
|-----------------------|----|
| MY                    | 70 |
| MP                    | 80 |
| MR                    | 75 |

### Standard stepping motors

| Brand    | Max static torque | AC-Voltage | Stepping motor model  | Compatible driver model                 |
|----------|-------------------|------------|-----------------------|---|
| Tamagawa | 0.39              | DC24V      | 2-phase-TS3653N1E2    | CD-2D34M<br>200/400/800/1600 P/rev      |
| Oriental | 0.39              | DC24V      | 2-phase-PK264-02A     | CMD2120P<br>200/400/800/1600/3200 P/rev |
| Sanyo    | 0.39              | DC24V      | 2-phase-103H7121-0140 | CMD2120P<br>200/400/800/1600/3200 P/rev |

### Standard servo motors

| Brand      | Mark     | Brake                     | Wattp | AC-Voltage | Motor model   | Compatible driver model |
|------------|----------|---------------------------|-------|------------|---------------|-------------------------|
| Mitsubishi | <b>M</b> | No brake(Horizontal type) | 100   | 220        | HP-KP13       | MR-J3-10A               |
|            |          | With brake(Vertical type) | 100   | 220        | HP-KP13B      | MR-J3-10A               |
| Panasonic  | <b>P</b> | No brake(Horizontal type) | 100   | 220        | MSMD012P1S    | MADDT1205               |
|            |          | With brake(Vertical type) | 100   | 220        | MSMD012P1T    | MADDT1205               |
| Delta      | <b>T</b> | No brake(Horizontal type) | 100   | 220        | ECMA-C20401ES | ASD-B20121-B            |
|            |          | With brake(Vertical type) | 100   | 220        | ECMA-C20401FS | ASD-B20121-B            |

# METS-6M Stepping motor □57/Dimensions

## SLIDER ELECTRIC CYLINDER - BALL SCREW DRIVE (WITHOUT MOTOR)



**BC**  
Motor exposed

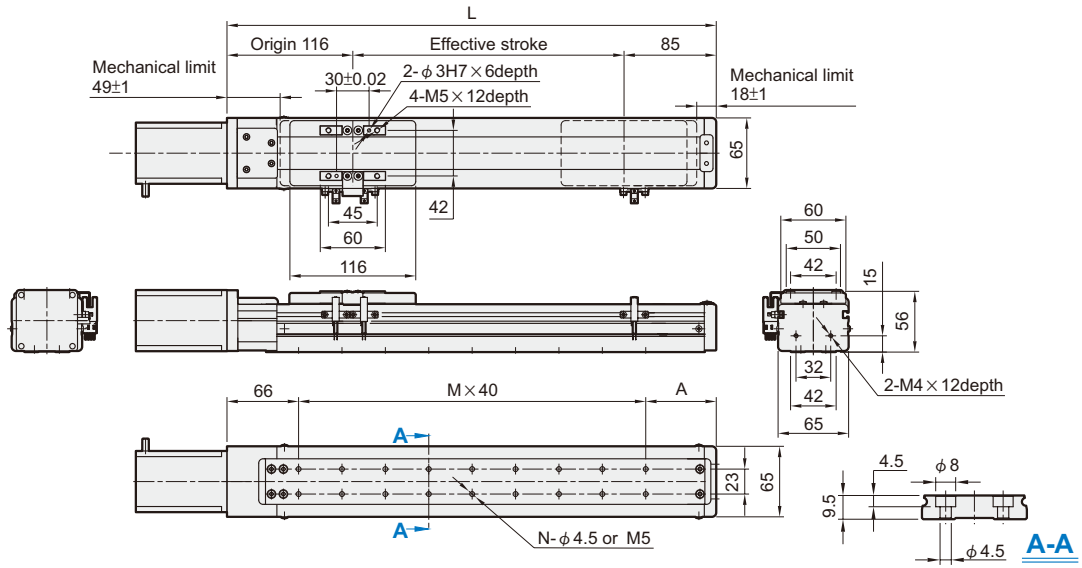

Unit: mm

| Stroke    | 100  | 150  | 200  | 250 | 300  | 350  | 400  | 450  | 500  | 550  | 600  | 650  | 700  | 750  | 800  |
|-----------|------|------|------|-----|------|------|------|------|------|------|------|------|------|------|------|
| <b>L</b>  | 301  | 351  | 401  | 451 | 501  | 551  | 601  | 651  | 701  | 751  | 801  | 851  | 901  | 951  | 1001 |
| <b>A</b>  | 35   | 45   | 55   | 65  | 35   | 45   | 55   | 65   | 35   | 45   | 55   | 65   | 35   | 45   | 55   |
| <b>M</b>  | 5    | 6    | 7    | 8   | 10   | 11   | 12   | 13   | 15   | 16   | 17   | 18   | 20   | 21   | 22   |
| <b>N</b>  | 12   | 14   | 16   | 18  | 22   | 24   | 26   | 28   | 32   | 34   | 36   | 38   | 42   | 44   | 46   |
| <b>KG</b> | 2.82 | 3.05 | 3.27 | 3.5 | 3.72 | 3.94 | 4.17 | 4.39 | 4.62 | 4.84 | 5.06 | 5.29 | 5.51 | 5.74 | 5.94 |

**BM**  
Motor on lower side

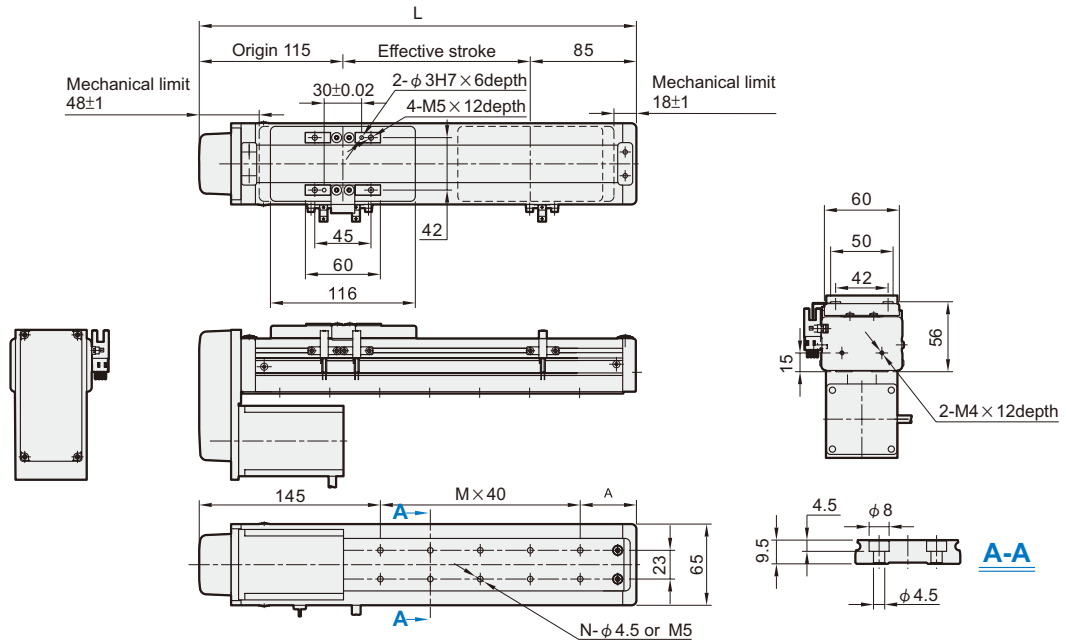

Unit: mm

| Stroke    | 100  | 150  | 200  | 250  | 300  | 350  | 400  | 450  | 500  | 550 | 600  | 650  | 700  | 750 | 800  |
|-----------|------|------|------|------|------|------|------|------|------|-----|------|------|------|-----|------|
| <b>L</b>  | 300  | 350  | 400  | 450  | 500  | 550  | 600  | 650  | 700  | 750 | 800  | 850  | 900  | 950 | 1000 |
| <b>A</b>  | 35   | 45   | 55   | 65   | 35   | 45   | 55   | 65   | 35   | 45  | 55   | 65   | 35   | 45  | 55   |
| <b>M</b>  | 3    | 4    | 5    | 6    | 8    | 9    | 10   | 11   | 13   | 14  | 15   | 16   | 18   | 19  | 20   |
| <b>N</b>  | 8    | 10   | 12   | 14   | 18   | 20   | 22   | 24   | 28   | 30  | 32   | 34   | 38   | 40  | 42   |
| <b>KG</b> | 2.86 | 3.09 | 3.31 | 3.54 | 3.77 | 3.99 | 4.22 | 4.44 | 4.67 | 4.9 | 5.12 | 5.35 | 5.57 | 5.8 | 5.99 |

# METS-6M Stepping motor □57/Dimensions

## SLIDER ELECTRIC CYLINDER - BALL SCREW DRIVE (WITHOUT MOTOR)



**BL**  
Motor on left side

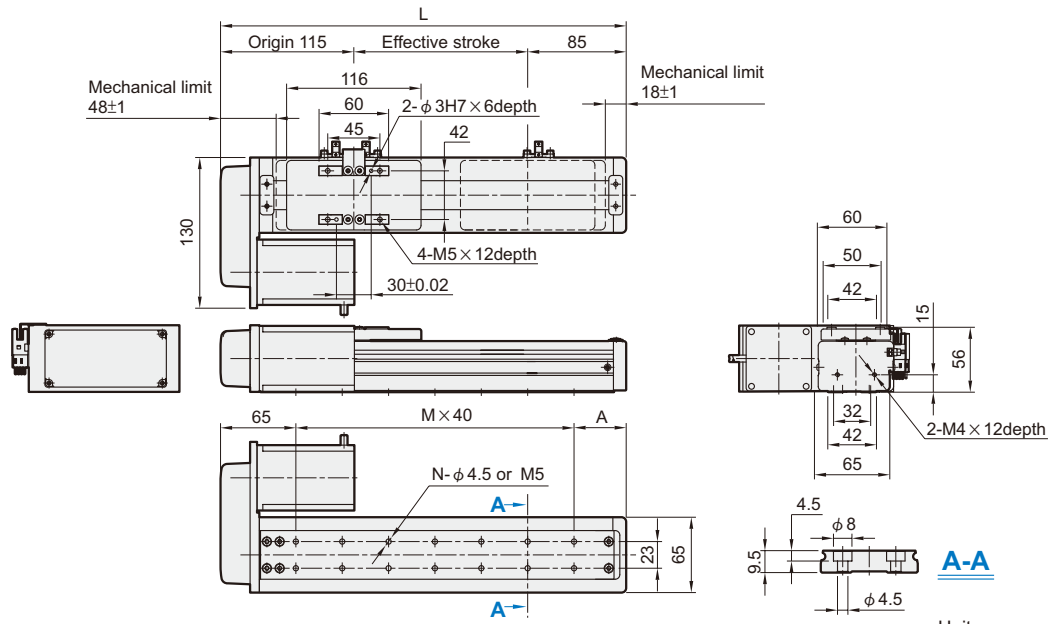

Unit: mm

| Stroke    | 100  | 150  | 200  | 250  | 300  | 350  | 400  | 450  | 500  | 550 | 600  | 650  | 700  | 750 | 800  |
|-----------|------|------|------|------|------|------|------|------|------|-----|------|------|------|-----|------|
| <b>L</b>  | 300  | 350  | 400  | 450  | 500  | 550  | 600  | 650  | 700  | 750 | 800  | 850  | 900  | 950 | 1000 |
| <b>A</b>  | 35   | 45   | 55   | 65   | 35   | 45   | 55   | 65   | 35   | 45  | 55   | 65   | 35   | 45  | 55   |
| <b>M</b>  | 5    | 6    | 7    | 8    | 10   | 11   | 12   | 13   | 15   | 16  | 17   | 18   | 20   | 21  | 22   |
| <b>N</b>  | 12   | 14   | 16   | 18   | 22   | 24   | 26   | 28   | 32   | 34  | 36   | 38   | 42   | 44  | 46   |
| <b>KG</b> | 2.86 | 3.09 | 3.31 | 3.54 | 3.77 | 3.99 | 4.22 | 4.44 | 4.67 | 4.9 | 5.12 | 5.35 | 5.57 | 5.8 | 5.99 |

**BR**  
Motor on right side

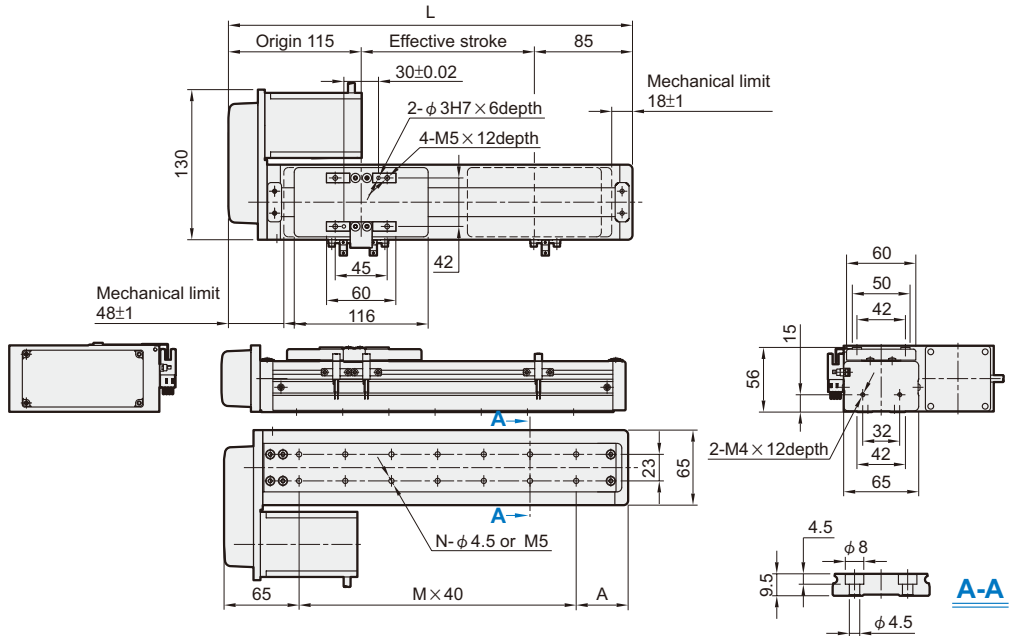

Unit: mm

| Stroke    | 100  | 150  | 200  | 250  | 300  | 350  | 400  | 450  | 500  | 550 | 600  | 650  | 700  | 750 | 800  |
|-----------|------|------|------|------|------|------|------|------|------|-----|------|------|------|-----|------|
| <b>L</b>  | 300  | 350  | 400  | 450  | 500  | 550  | 600  | 650  | 700  | 750 | 800  | 850  | 900  | 950 | 1000 |
| <b>A</b>  | 35   | 45   | 55   | 65   | 35   | 45   | 55   | 65   | 35   | 45  | 55   | 65   | 35   | 45  | 55   |
| <b>M</b>  | 5    | 6    | 7    | 8    | 10   | 11   | 12   | 13   | 15   | 16  | 17   | 18   | 20   | 21  | 22   |
| <b>N</b>  | 12   | 14   | 16   | 18   | 22   | 24   | 26   | 28   | 32   | 34  | 36   | 38   | 42   | 44  | 46   |
| <b>KG</b> | 2.86 | 3.09 | 3.31 | 3.54 | 3.77 | 3.99 | 4.22 | 4.44 | 4.67 | 4.9 | 5.12 | 5.35 | 5.57 | 5.8 | 5.99 |

# METS-6M Servo motor 100W/Dimensions

## SLIDER ELECTRIC CYLINDER - BALL SCREW DRIVE (WITHOUT MOTOR)



**BC**  
Motor exposed

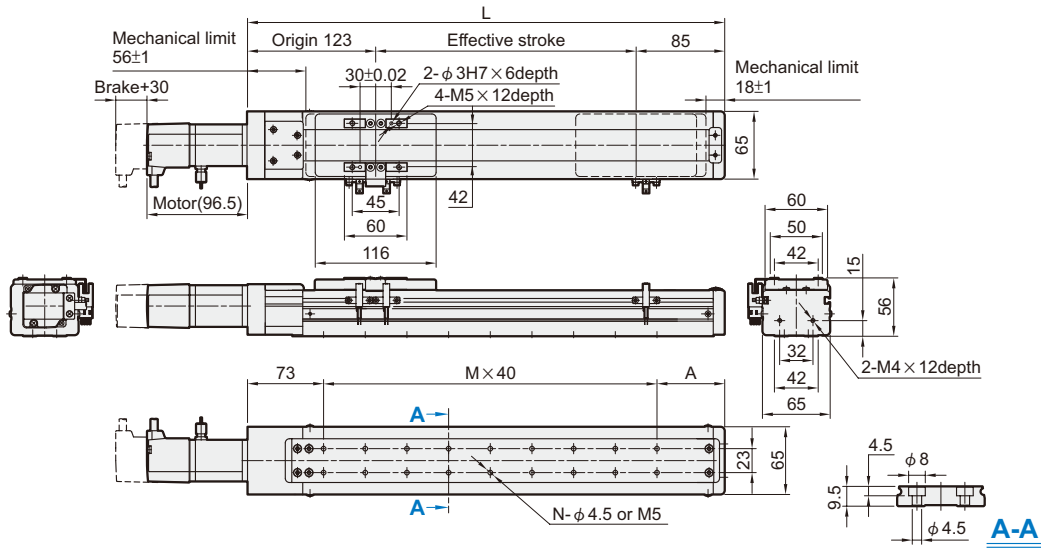

Unit: mm

| Stroke    | 100  | 150  | 200  | 250 | 300  | 350  | 400  | 450  | 500  | 550  | 600  | 650  | 700  | 750  | 800  |
|-----------|------|------|------|-----|------|------|------|------|------|------|------|------|------|------|------|
| <b>L</b>  | 308  | 358  | 408  | 458 | 508  | 558  | 608  | 658  | 708  | 758  | 808  | 858  | 908  | 958  | 1008 |
| <b>A</b>  | 35   | 45   | 55   | 65  | 35   | 45   | 55   | 65   | 35   | 45   | 55   | 65   | 35   | 45   | 55   |
| <b>M</b>  | 5    | 6    | 7    | 8   | 10   | 11   | 12   | 13   | 15   | 16   | 17   | 18   | 20   | 21   | 22   |
| <b>N</b>  | 12   | 14   | 16   | 18  | 22   | 24   | 26   | 28   | 32   | 34   | 36   | 38   | 42   | 44   | 46   |
| <b>KG</b> | 2.82 | 3.05 | 3.27 | 3.5 | 3.72 | 3.94 | 4.17 | 4.39 | 4.62 | 4.84 | 5.06 | 5.29 | 5.51 | 5.74 | 5.94 |

**BM**  
Motor on lower side

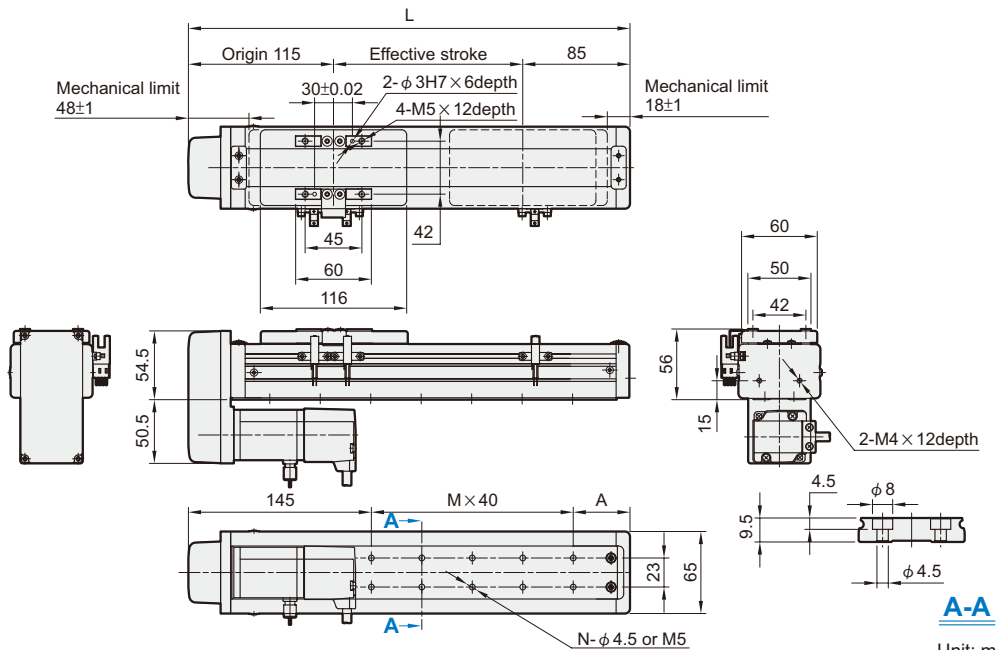

Unit: mm

| Stroke    | 100  | 150  | 200  | 250  | 300  | 350  | 400  | 450  | 500  | 550 | 600  | 650  | 700  | 750 | 800  |
|-----------|------|------|------|------|------|------|------|------|------|-----|------|------|------|-----|------|
| <b>L</b>  | 300  | 350  | 400  | 450  | 500  | 550  | 600  | 650  | 700  | 750 | 800  | 850  | 900  | 950 | 1000 |
| <b>A</b>  | 35   | 45   | 55   | 65   | 35   | 45   | 55   | 65   | 35   | 45  | 55   | 65   | 35   | 45  | 55   |
| <b>M</b>  | 3    | 4    | 5    | 6    | 8    | 9    | 10   | 11   | 13   | 14  | 15   | 16   | 18   | 19  | 20   |
| <b>N</b>  | 8    | 10   | 12   | 14   | 18   | 20   | 22   | 24   | 28   | 30  | 32   | 34   | 38   | 40  | 42   |
| <b>KG</b> | 2.86 | 3.09 | 3.31 | 3.54 | 3.77 | 3.99 | 4.22 | 4.44 | 4.67 | 4.9 | 5.12 | 5.35 | 5.57 | 5.8 | 5.99 |

# METS-6M Servo motor 100W/Dimensions

## SLIDER ELECTRIC CYLINDER - BALL SCREW DRIVE (WITHOUT MOTOR)



mindman

**BL**

Motor on left side

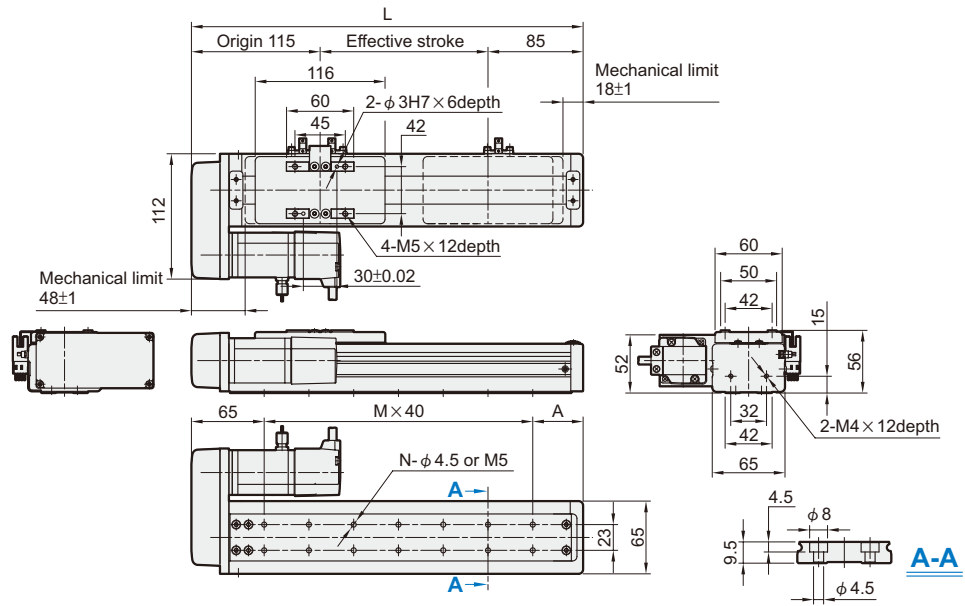

Unit: mm

| Stroke    | 100  | 150  | 200  | 250  | 300  | 350  | 400  | 450  | 500  | 550 | 600  | 650  | 700  | 750 | 800  |
|-----------|------|------|------|------|------|------|------|------|------|-----|------|------|------|-----|------|
| <b>L</b>  | 300  | 350  | 400  | 450  | 500  | 550  | 600  | 650  | 700  | 750 | 800  | 850  | 900  | 950 | 1000 |
| <b>A</b>  | 35   | 45   | 55   | 65   | 35   | 45   | 55   | 65   | 35   | 45  | 55   | 65   | 35   | 45  | 55   |
| <b>M</b>  | 5    | 6    | 7    | 8    | 10   | 11   | 12   | 13   | 15   | 16  | 17   | 18   | 20   | 21  | 22   |
| <b>N</b>  | 12   | 14   | 16   | 18   | 22   | 24   | 26   | 28   | 32   | 34  | 36   | 38   | 42   | 44  | 46   |
| <b>KG</b> | 2.86 | 3.09 | 3.31 | 3.54 | 3.77 | 3.99 | 4.22 | 4.44 | 4.67 | 4.9 | 5.12 | 5.35 | 5.57 | 5.8 | 5.99 |

**BR**

Motor on right side

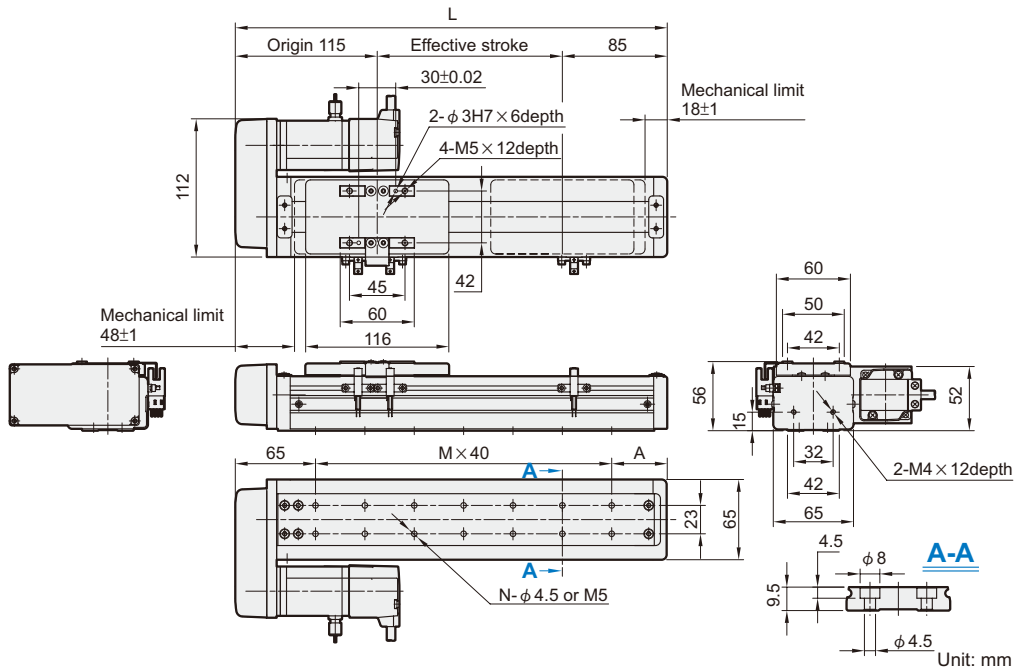

Unit: mm

| Stroke    | 100  | 150  | 200  | 250  | 300  | 350  | 400  | 450  | 500  | 550 | 600  | 650  | 700  | 750 | 800  |
|-----------|------|------|------|------|------|------|------|------|------|-----|------|------|------|-----|------|
| <b>L</b>  | 300  | 350  | 400  | 450  | 500  | 550  | 600  | 650  | 700  | 750 | 800  | 850  | 900  | 950 | 1000 |
| <b>A</b>  | 35   | 45   | 55   | 65   | 35   | 45   | 55   | 65   | 35   | 45  | 55   | 65   | 35   | 45  | 55   |
| <b>M</b>  | 5    | 6    | 7    | 8    | 10   | 11   | 12   | 13   | 15   | 16  | 17   | 18   | 20   | 21  | 22   |
| <b>N</b>  | 12   | 14   | 16   | 18   | 22   | 24   | 26   | 28   | 32   | 34  | 36   | 38   | 42   | 44  | 46   |
| <b>KG</b> | 2.86 | 3.09 | 3.31 | 3.54 | 3.77 | 3.99 | 4.22 | 4.44 | 4.67 | 4.9 | 5.12 | 5.35 | 5.57 | 5.8 | 5.99 |