

MEHC-20 series

ELECTRIC GRIPPER (WITH MOTOR)

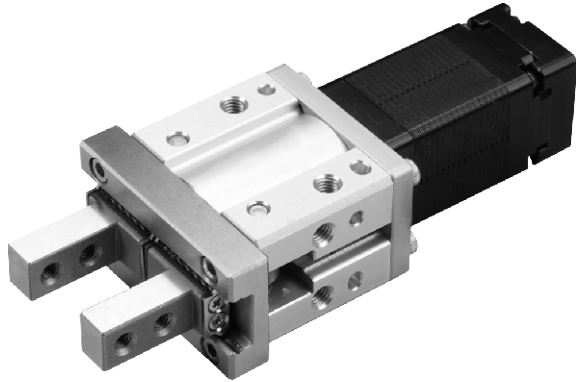

mindman



Specification

Model	MEHC-20
Gripper force (N)	22~98
Open and close stroke (mm) ※1	10
Open and close speed (mm/s)	5~50
Position repeatability (mm)	±0.02
Guide structure	Linear guide
Operating temperature range (°C)	0~+40
Operating humidity range (%)	Below RH90
Motor dimension (mm)	□ 25
Weight (g) ※2	368

※1.Total stroke of both sides.

※2.Weight of model with motor.

Order example of gripper

MEHC-20 — **S10** — **TC100** — **03** — **A0001**

Model Spec. ACME lead screw Corresponding controller Cable length Special order no.

ACME lead screw	Corresponding controller	Cable length
S10 Standard type	TC100	01 1m
N10 Narrow type	※ Please refer to 4-126.	03 3m
		05 5m
		10 10m

※ Standard: 3m

Order example of controller

TC100 — **03**

Controller Cable length

Controller	Cable length
TC100	Blank No cable
	01 1m
	03 3m
	05 5m
	10 10m

※ Standard: 3m

Allowable moment and force (N.m / N)

Maximum moment	
MY	1.32 (N.m)
MP	1.32 (N.m)
MR	2.65 (N.m)
Maximum force	
FV	147 (N)

※MY: Allowable yawing moment
 ※MP: Allowable pitching moment
 ※MR: Allowable rolling moment
 ※FV: Vertical maximum force

※L: Distance to the loading location (mm).

Gripping power VS. Gripping power setting

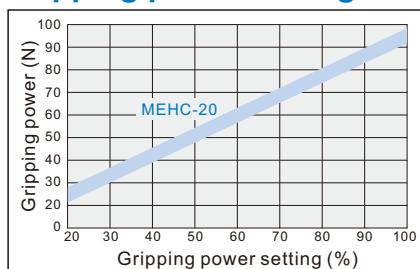

MEHC-20 Dimensions

ELECTRIC GRIPPER (WITH MOTOR)



S10 Standard type

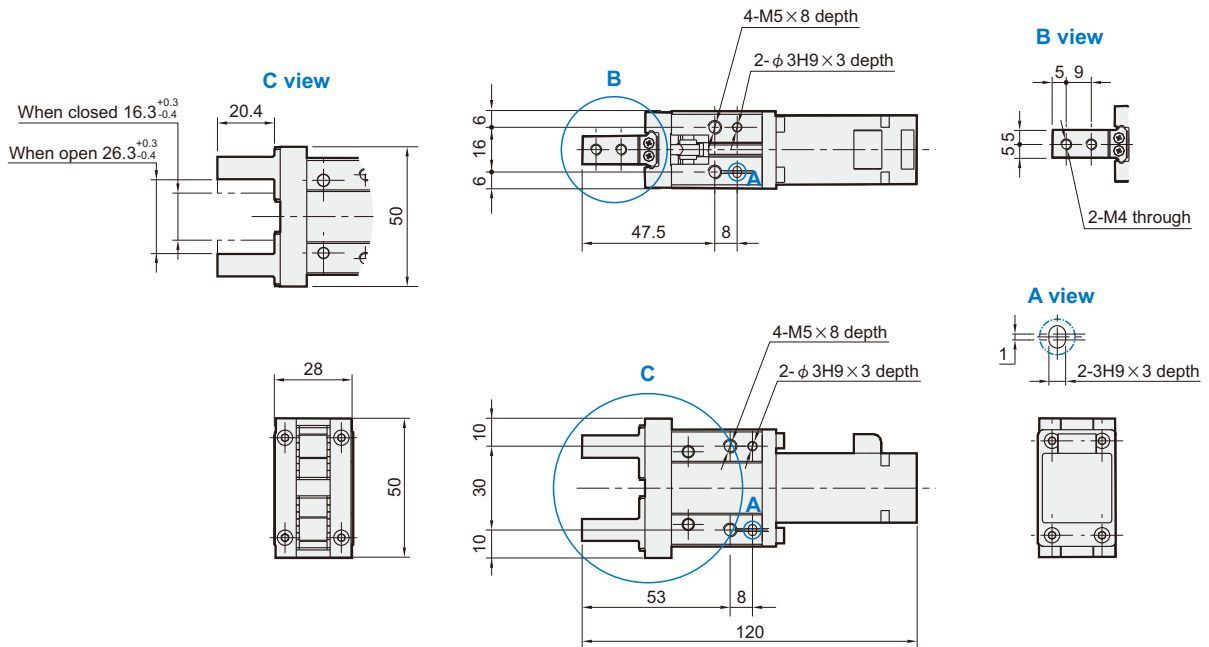

N10 Narrow type

