

Features

- Aluminium alloy tube provides both smooth lines and high corrosion resistance.
- Self lubricated nose bush gives long life.
- Versatile porting position available.
- End cushioning at both ends reduces impact loads.

Specification

Model	MCKA
Acting type	Double acting
Tube I.D. (mm)	40
Medium	Air
Operating pressure range	0.05~1 MPa
Test pressure	1.5 MPa
Temperature range	-5~ +60°C (No freezing)
Lubrication	Not required
Available speed range	50~500 mm/sec
Cushion	With adjustable cushion at both ends
Sensor switch (※)	RCA
Sensor switch holder	PN-A40

※ RCA specification, please refer to page 5-2.

Order example

MCKA - 40 - 100 M - A

MODEL

TUBE I.D.

STROKE

50
75
100
125
150

M: Magnet

Blank: With adjustable cushion
A: With flow adjustable

Application examples

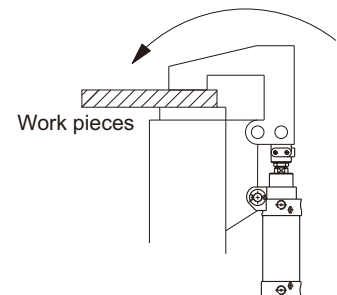
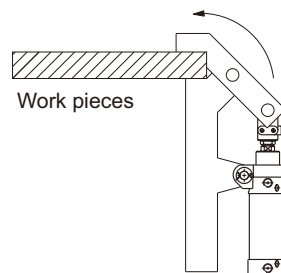
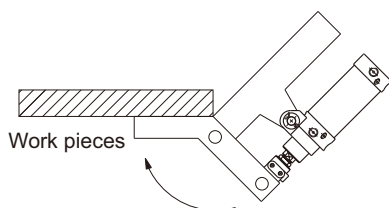

CLAMP CYLINDER

Mindman

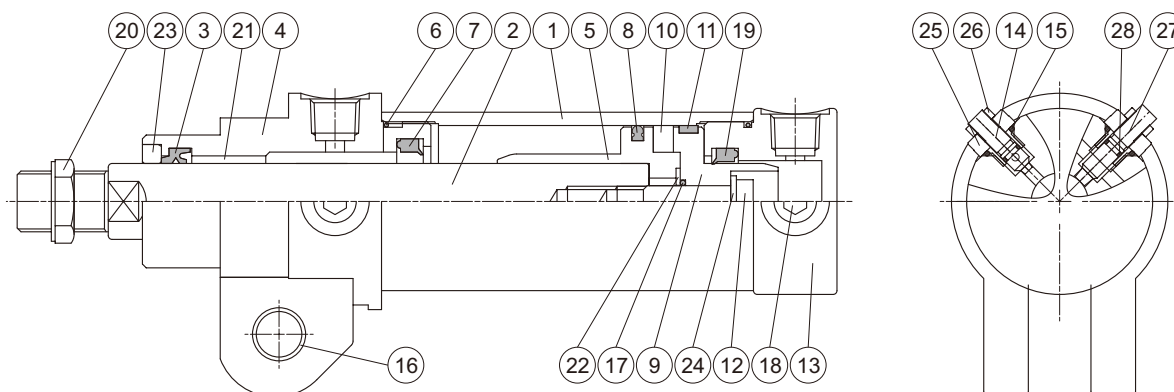

Material

No.	Part name	Material	Q'y	Component parts (inclusion)	Repair kits (inclusion)
1	Tube	Aluminum alloy	1		
2	Piston rod	Carbon steel	1		
3	Rod packing	NBR	1	●	●
4	Rod cover	Carbon steel	1	●	
5	Piston-R	Aluminum alloy	1	●	
6	Cover ring	NBR	2	●	●
7	Cushing packing-R	NBR	1	●	●
8	Piston packing	NBR	1	●	●
9	Piston-H	Aluminum alloy	1	●	
10	Magnet ring	Magnet material	1	●	
11	Wear ring	Teflon	1	●	
12	Piston bolt	SCM	1	●	
13	Head cover	Aluminum alloy	1	●	
14	Cushion needle valve	Copper	2	●	
15	Need valve packing	NBR	4	●	●
16	Bush	Copper	2	●	
17	Piston gasket	NBR	1	●	●
18	Seal screw	Carbon steel	4	●	
19	Cushion packing-H	NBR	1	●	●
20	Rod front nut	Carbon steel	1	●	
21	Rod bush	Copper	1	●	
22	Washer	Carbon steel	1	●	
23	Scraper	Copper	1	●	
24	Washer	Carbon steel	1	●	
25	Lock nut for need valve	Copper	4	●	
26	Adj. nut for need valve	Copper	4	●	
27	Flow needle valve	Copper	2	●	
28	Need valve packing	NBR	4	●	●

Order example of component parts / repair kits

Tube I.D.	Component parts	Repair kits
φ 40	CP-MCKA-40	PS-MCKA-40

CLAMP CYLINDER

Construction

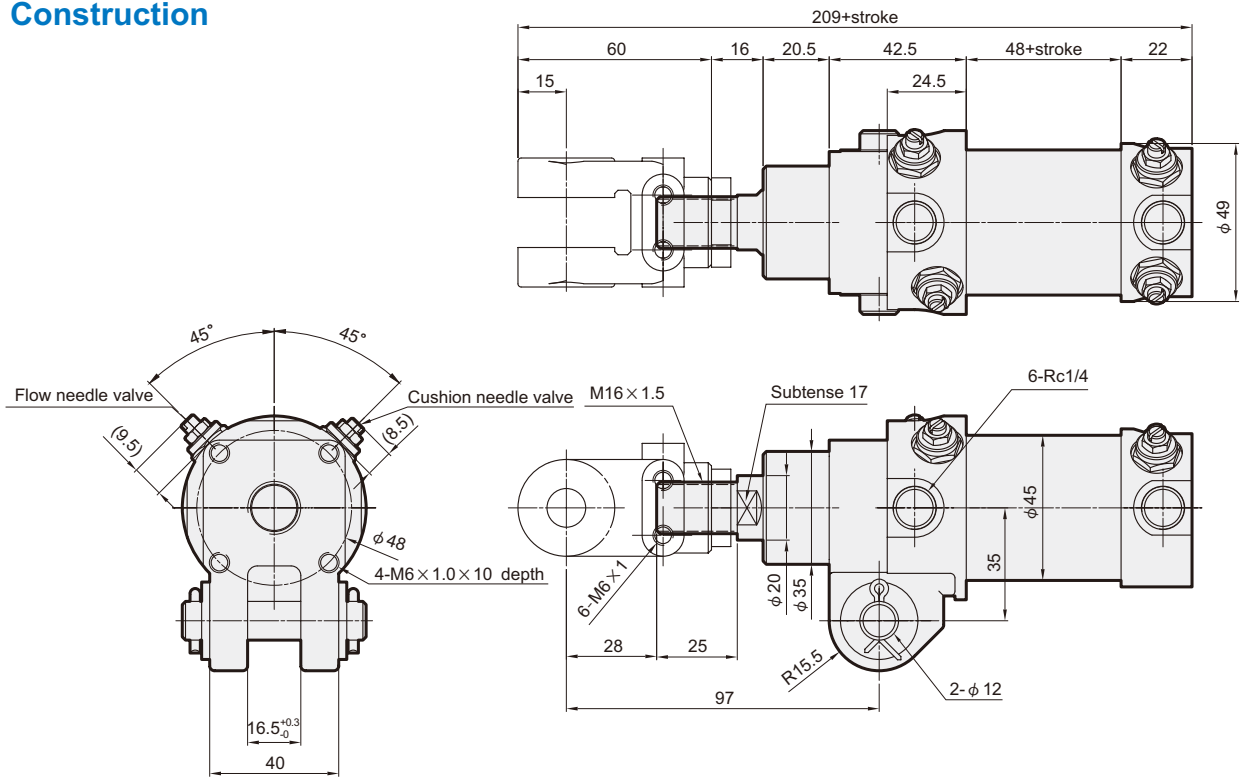

I connector

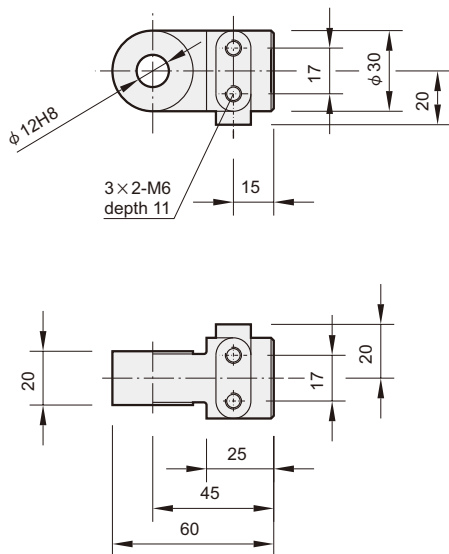

Y connector

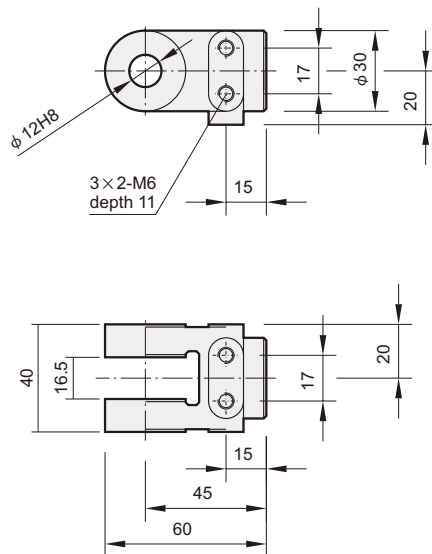

Pin

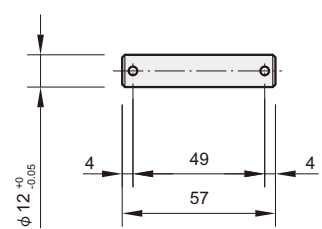

Split pin: $\phi 1/8" \times 3/4" L$