

MACT300L series

AIR UNIT (F.R.L.UNIT)



mindman



- Longer case for adapting high efficient auto drain valve.

Specification

Model	MACT300L	
Components	MAF300L, MAR301, MAL300L	
Bore No.	8A	10A
Port size	1/4	3/8
Medium	Air	
Operating pressure range (※)	0.05~1 MPa	
Proof pressure	1.5MPa	
Effective orifice	32mm ²	34mm ²
Regulated pressure range	0.05~0.85 MPa	
Ambient temperature	- 5~+ 60°C (No freezing)	
Filter element	Standard: 5 μm Option: 40 μm	
Lubricating oil capacity	65 c.c	
Min. Flow for oil drip	50 ℓ/min	60 ℓ/min
Recommended lubricating oil	Turbine oil ISO-VG32	
Attachment	Pressure gauge(PG-40), T-type bracket	
Weight	959 g	

Symbol

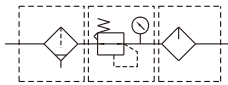

Order example

MACT300L – 8A – D – □ – T8 – □

MODEL

BORE SIZE

8A: 1/4
10A: 3/8

D: Auto drain valve (FMRF300)
N: Nylon bowl

FILTER ELEMENT
Blank: 5 μm
40u: 40 μm

Module mounting bracket
T8: 1/4
T10: 3/8

PORT THREAD
Blank: Rc thread
G: G thread
NPT: NPT thread

- ※1. Standard unit contains semi-auto-drain function when operating pressure below 0.05 MPa.
- ※2. Choose auto-drain FMRF300, the pressure range is 0.15 ~ 1 MPa.

Flow feature

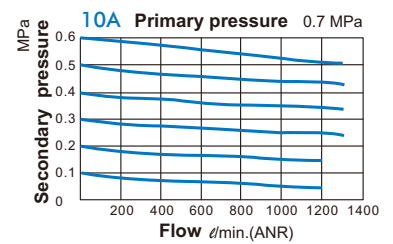
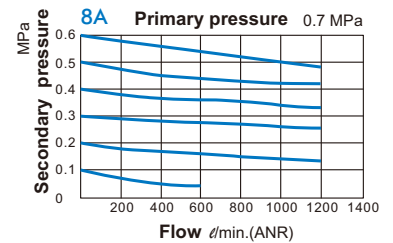

MACT300L-D Auto drain valve

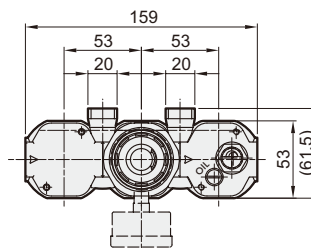
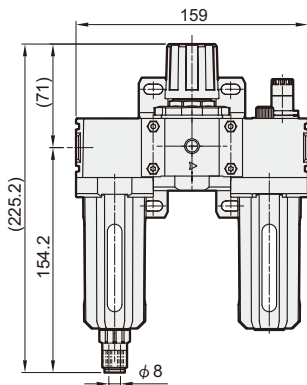

MACT300L-T* Module mounting bracket

