

# MACP400 series

AIR UNIT (F.R.L.UNIT)

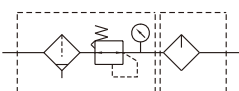

## Symbol



## Order example

MACP400 – 10A – D – □ – □

MODEL

BORE SIZE

8A: 1/4  
10A: 3/8  
15A: 1/2

FILTER ELEMENT

Blank: 40 μm  
5u: 5 μm

D: Auto drain valve (FMRF300)  
N: Nylon bowl

PORT THREAD  
Blank: Rc thread  
G: G thread  
NPT: NPT thread

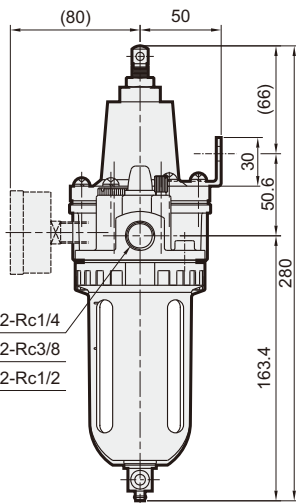
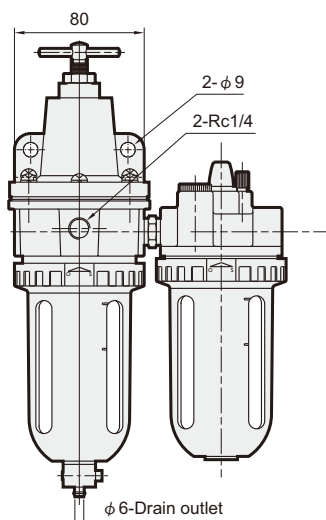
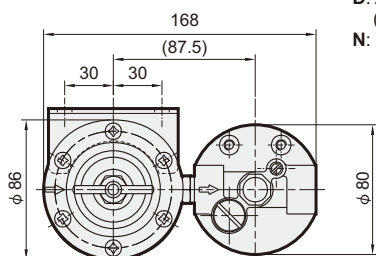

## Specification

Model	MACP400		
Components	MAFR400, MAL400		
Bore No.	8A	10A	15A
Port size	1/4	3/8	1/2
Medium	Air		
Operating pressure range (※)	0.05~1 MPa		
Proof pressure	1.5 MPa		
Regulated pressure range	0.05~0.85 MPa		
Ambient temperature	-5~+60°C (No freezing)		
Filter element	Standard: 40 μm Option: 5 μm		
Lubricating oil capacity	200 c.c		
Min. flow for oil drip	50 ℓ/min	200 ℓ/min	400 ℓ/min
Recommended lubricating oil	Turbine oil ISO-VG32		
Attachment	Pressure gauge(PG-50), bracket		
Weight	2300 g		

※1. Standard unit contains semi-auto-drain function when operating pressure below 0.05 MPa.

※2. Choose auto-drain FMRF300, the pressure range is 0.15 ~ 1 MPa.

## Flow feature

